

5A-75B Receiving Card

Overview

5A-75B receiving card was Colorlight special introduced high performance product that designed for customers to save cost, reduce points of fault and failure rate.

Based on 5A receiving card, 5A-75B integrates the most common HUB75 interfaces, which is more reliable and more economical on the premise that ensure high-quality display.

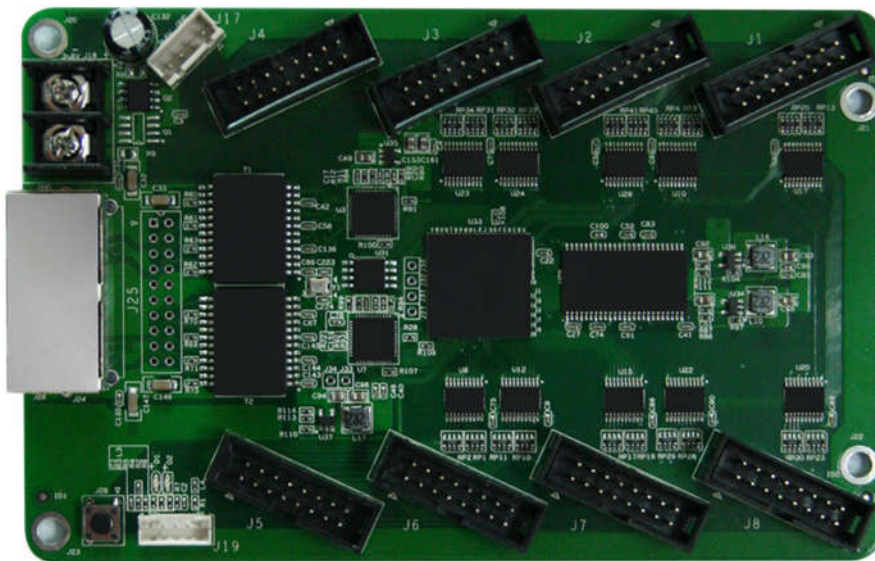

Features

- Integrated HUB75 interface, more convenient with less cost.
- Reduce the plug connectors and malfunction, lower failure rate.
- Superior display quality: high refresh rate, high grayscale, and high brightness with the conventional chips.
- Perfect performance under lower grayscale status.
- Better detail processing: Partial dark at row, reddish at low gray, shadow problems can be solved.
- Support 14 bits high-precision point-by-point calibration in the Brightness and the chromaticity.
- Support conventional chips, PWM chips and lighting chips.
- Support any scan mode from static to 1/32 scan.
- Support any pumping point and data arbitrary offset and realize various

freeform display, spherical display, creative display, etc.

- Support 16 groups of RGB signal output.
- Large load capacity.
- Advanced design, high quality components, rigorous aging test, zero malfunction of final products.
- First adopt all components face up configuration to reduce damage.
- Wide working voltage range with DC3.3~6V.
- Compatible with iT7, iQ7, iQ7E, Gigabit NIC, C series Sender, etc.

Specifications

Control system parameters	
Sending device	iT7 Sender , iQ7 HD Sender, iQ7E UHD Sender, Gigabit NIC,C series Sender, etc
Control area of every card	Full-color: 256*256 Pixels, for special applications the column can be extended to 1024 pixels
Correction area of every card	256*256 Pixels
Cascade control area of the largest regional	65536*65536 pixels
Cascade card number	65536 PCS
Network port exchange	Support, arbitrary use
Synchronization	Nanosecond synchronization between cards
Display Quality	
Refresh rate for conventional chip	Static: 64*64, up to 16000Hz 1/8 scan: 128*128, up to 10000Hz
Serial frequency	0.2MHz-41.7MHz
Gray Level	Maximum 65536 levels
Minimum unit of OE values	8ns, 8ns multiples steps
Gray scale compensation	Each level grayscale compensate separately
Display module compatibility	
Chip supports	Support conventional chips, PWM chips, lighting chips and other mainstream chips
PWM chip supports	Support hundreds of different specifications of the PWM chip, such as MBI, MY, SUM, etc
Scan mode	Conventional mode and high refresh rate mode to support refresh rate multiplied

Scan type	Support 1/32 scan
module specifications Support	Support 4096 pixels within any row, any column
The direction of the cable	Support route from left to right, from right to left, from top to bottom, from bottom to top.
Data Groups	16 RGB data groups
Data folded	Support to fold on the same or opposite direction, which improve refresh rate significantly
Data exchange	16 data groups for any exchange
Module snapshot	Support any pumping point
Data serial transmission	Support RGB, R8G8B8, R16G16B16, etc in the form of serial
Compatible device and interface type	
Communication distance	UTP cable≤140M CAT6 cable≤170M Optic fiber:Single Mode Fiber Transceivers≤20KM Multi-Mode Fiber Transceiver ≤550M (Use RP Repeater to extend unlimited)
Compatible with transmission equipment	Gigabit switch, fiber transceiver, optical switches
DC power interface	Wire terminal
HUB Interface Type	HUB75 (Note: 32 scan with E signal)
Physical parameters	
Size	143* 93mm
Input voltage	DC 3.3V-6V
Rated current	0.6A
Rated power consumption	3W
Storage and transport temperature	-50℃ to 125℃
Operating Temperature	-25℃ to 75℃
Body static resistance	2KV
Weight	100g
Monitoring Functions (in conjunction with multi-function card)	
Monitoring functions	Real time monitoring environment information like temperature, humidity, smog

Remote Control	Support for relay switch to turn on/off the power supply of equipments remotely
pixel level calibration	
Brightness calibration	Support
Chromaticity calibration	Support
Other features	
Hot backup	Support, from A to B, and loop backup as well
Shaped screen	Support various freeform display, spherical display, creative display, etc. through the data arbitrary offset.

Hardware

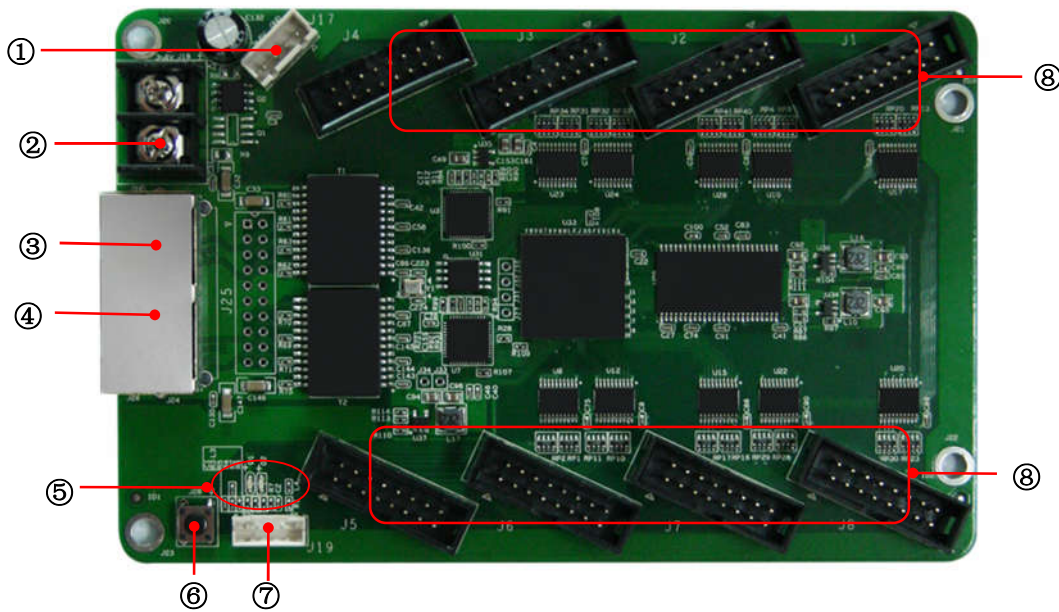

1. Interface

S/N	Name	Function	Remarks
1	Power 1	Connect DC 3.3~6V power supply for the receiving card	Only one is used.
2	Power 2	Connect DC 3.3~6V power supply for the receiving card	
3	Network port A	RJ45 , For transmitting data signals	The dual network ports can achieve import/export at random, which can be identified in an intelligent way by the system.
4	Network port B	RJ45 , For transmitting data signals	
5	Power/Signal Indicator light	D1 power indicator light D2 signal transmission status	red for power, green for signal
6	Test button	The attached test procedures can achieve four kinds of monochrome display (red, green, blue and white), as well as horizontal, vertical and other display scan modes.	
7	External interfaces	For Indicator light and test button	
8	HUB pins	HUB75 Interface, J1~J8 connected to display modules	Support 32 scan with E signal

2. Indicator Light functions

Red: ON for power available

Green: ON/OFF quick flash (about 5-10 times/second) indicates that the data signal transmission is normal.

3. Definitions of HUB75

Data signal				Scanning signal		Control signal	
GD1	GND	GD1	E	B	D	LAT	GND
2	4	6	8	10	12	14	16
1	3	5	7	9	11	13	15
RD1	BD1	RD1	BD1	A	C	CLK	OE
Data signal				Scanning signal		Control signal	

Note: Onboard HUB75 Interface Contains E scanning signal, supporting 32 scan display.

4. Definition of External Interface

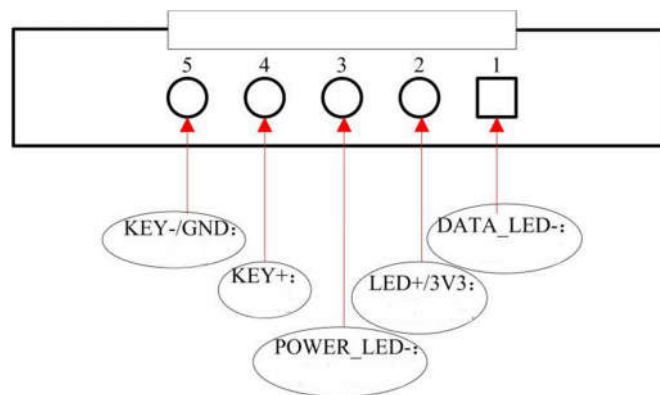

5. Figure for receiving card size and hole position

