

i6 Receiver Card

Overview

i6 is COLORLIGHT special introduced high-end and all-purpose receiver card, featuring a small size with 68*33mm; it is adopt DDR2 SODIMM interface, can be easily integrated into the HUB board or unit plate of LED display, and achieves the high integration of the LED display module, which greatly facilitates the design of the LED display unit panel and structure.

i6 has all the functions of the mainstream receiver card. Besides, it has also developed a series of practical and powerful functions for the high-end display screen, improving the added value of the custom product.

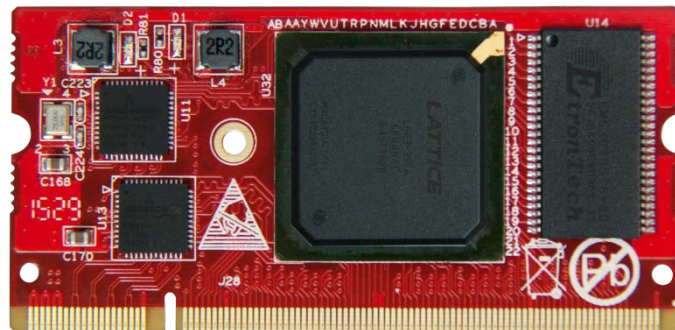

Features

- Support 32 groups of RGB signal output.
- Large load capacity of 256*256 pixels for each card;
- Support high-precision point-by-point calibration in the Brightness and the chromaticity;

- Support smart module, save calibration coefficients and module parameters on module ;
- Support 'cabinet' s temperature, humidity, power supply voltage monitoring and fan rotating control
- Support the cable detection
- Support error detection of LED on module point- by –point ;
- Support the receiver card double backup and power supply double backup;
- Support any scan mode from static to 1/32 scan;
- Support various freeform display, spherical display, creative display, etc.
- Wide working voltage range with DC3.3 -6V;
- Superior versatile, supporting Gigabit Ethernet, T7 sending cards, Q7 HD transmitter, network video system, etc. all conventional sending equipment

Specifications

Control system parameters	
Sending device	iT7 Sender , iQ7 HD Sender, iQ7E UHD Sender, Gigabit NIC, C1 Series Sender, T8 , etc.
Control area of every card	Full-color: 256*256 Pixels,
Cascade control area of the largest regional	65536*65536 Pixels
Network port exchange	Support, arbitrary use
Gray Level	Maximum 65536 Levels
Display module compatibility	
Chip supports	Support conventional chips, PWM chips, lighting chips and other mainstream chips.
Scan mode	Two scanning methods to support refresh rate multiplier
Scan type	Support static sweep to 1/32 scan
module specifications	Support 4096 pixels within any row, any column

Support	
The direction of the cable	Support route from left to right, from right to left, from top to bottom, from bottom to top.
Data Sets	32 RGB data sets
Data folded	Support 1~8 any discount to improve refresh rate.
Data exchange	32 sets of data any exchange
Module snapshot	Support any pumping point
Compatible device and interface type	
Communication distance	UTP cable≤140M CAT6 cable≤170M OPTIC FIBER transmission distance unrestricted
Compatible with transmission equipment	Gigabit switch, fiber transceiver, optical switches.
Size	67.6*32.9mm
Input voltage	DC 3.3V~6V
Rated current	0.6A
Rated power	3W
Storage and transport temperature	-50°C~125°C
Operating Temperature	-25°C~75°C
Body static resistance	2KV
weight	9.5g
Monitoring function (in conjunction with multi-function card)	
Temperature monitoring	monitoring cabinet temperature range with -25°C~75°C 1 sensor for each card
Humidity monitoring	Connect line 1 to monitoring receiver card humidity range with 20%~95% 1 sensor for each card
Bit error monitoring	Monitoring the total number of data packets, error packets, to help check the network quality, eliminate hidden dangers
Supply voltage monitoring	Five-way
Smoke monitoring	Connect line 1 to monitoring the smoke normal or not, and can cooperate with relay to open the alarm and turn off the display screen 1 sensor for each card

Full color LCD display panel	Support
Pixel level calibration	
Brightness calibration	Support
Chromaticity calibration	Support
Other features	
hot backup	Support loop backup, double send backup, double sender card backup, double supply power backup, etc. many kinds type of hot backup
shaped screen	Support various freeform display, spherical display, creative display, etc. through the date arbitrary offset
Program backup	Proprietary rescue procedures, no matter how to use, upgrade, send parameters, never stop

Hardware

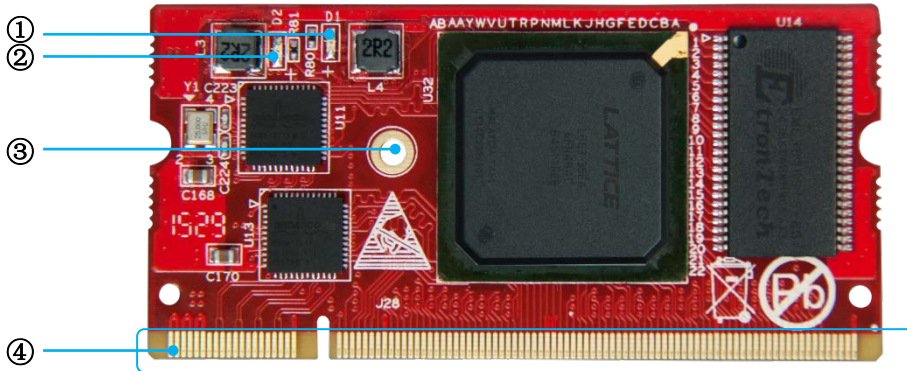

1. Interface

S/N	Name	Function	Remarks
1	Power indicate light	The indicate light always bright means the power supply is normal	
2	Signals indicate light	The indicate light bright and quick flash (about 5-10times/second) indicates that the data signal transmission is normal.	
3	Fixed hole	Used to reinforce the receiving card to improve the ability of resist vibration	
4	DDR interface	Being used in connection with display' s HUB board or unit plate	In this diagram, the leftside of the guide plate is first pin (Viewing from the front of card)

2. Figure for size and hole position

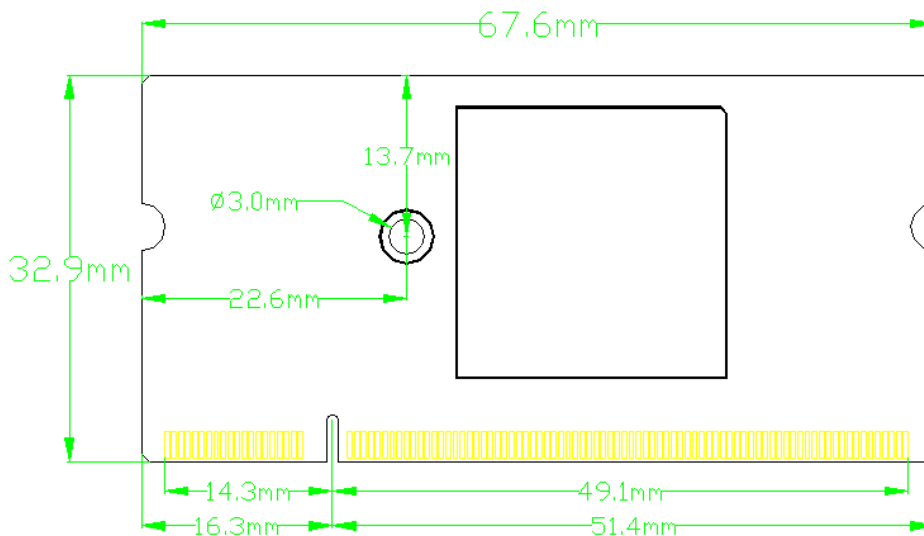

3、Definition of Pins

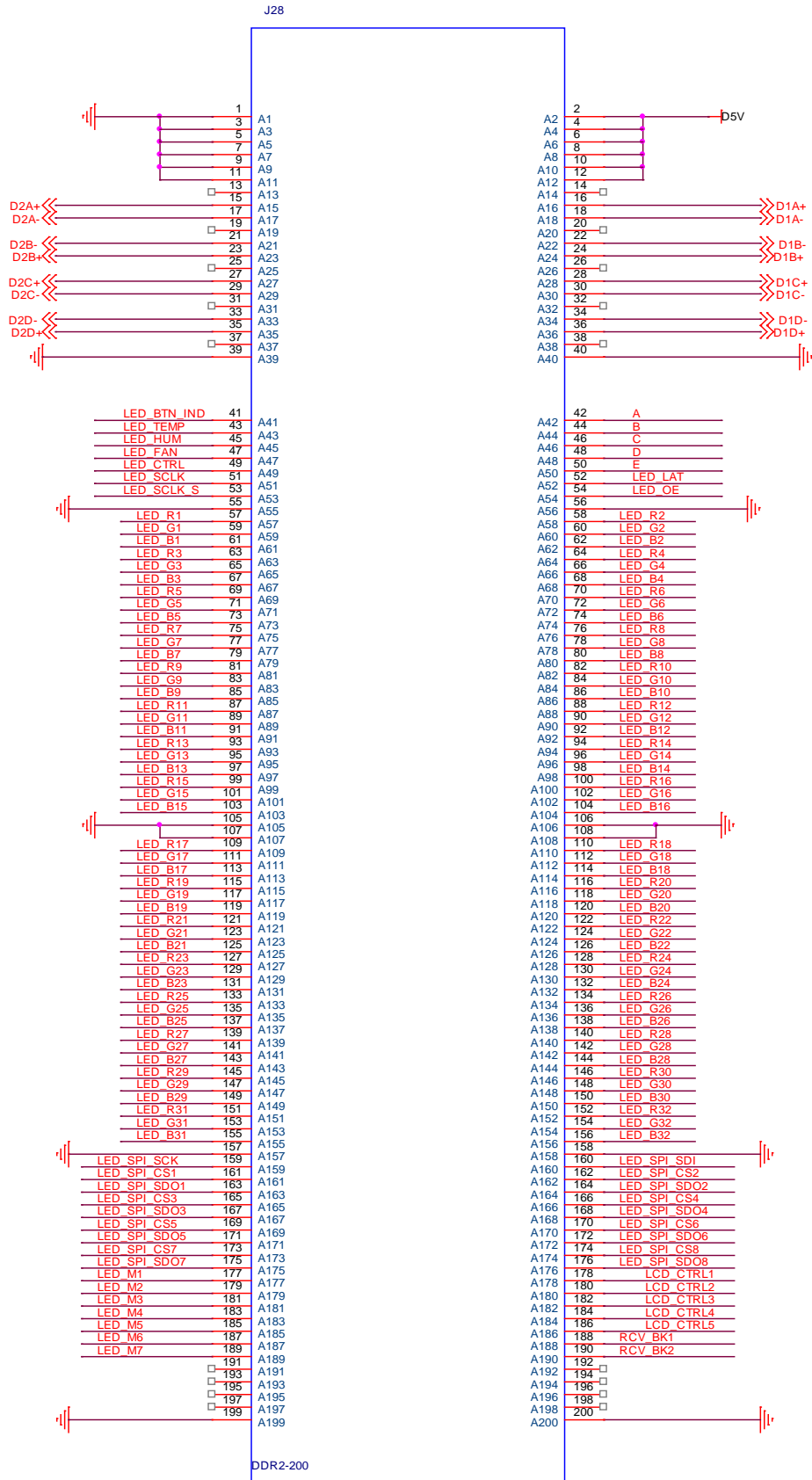

4、 Pins definition illustrate

Instructions	Definition	Pin No.		Definition	Instructions
Ground connection	GND	1	2	D5V	Power supply
	GND	3	4	D5V	
	GND	5	6	D5V	
	GND	7	8	D5V	
	GND	9	10	D5V	
	GND	11	12	D5V	
Do not connect	NC	13	14	NC	Do not connect
Network port 1 signal pin Recommended use isolation transformer	eth1_p1	15	16	eth2_p1	Network port 2 signal pin Recommended use isolation transformer
	eth1_n1	17	18	eth2_n1	
	NC	19	20	NC	
	eth1_n2	21	22	eth2_n2	
	eth1_p2	23	24	eth2_p2	
	NC	25	26	NC	
	eth1_p3	27	28	eth2_p3	
	eth1_n3	29	30	eth2_n3	
	NC	31	32	NC	
	eth1_n4	33	34	eth2_n4	
eth1_p4	35	36	eth2_p4		
Do not connect	NC	37	38	NC	Do not connect
Ground connection	GND	39	40	GND	Ground connection
Indicate light	LED_BTN_LED	41	42	A	Display control : 1、ABCDE for row decoding signal ; 2、LED_LAT for signal lock 3、LED_OEcontrol LED display enable , like a switch ,it is GCLK when the led display use PWM chip ;
Temperature monitoring	LED_TEMP	43	44	B	
Humility monitoring	LED_HUM	45	46	C	
Fan control	LED_FAN	47	48	D	
Blanking	LED_CTRL	49	50	E	
The first CLK	LED_SCLK	51	52	LED_LAT	
The second CLK	LED_SCLK_S	53	54	LED_OE	
	GND	55	56	GND	
RGB output of part A: A total of 8 groups of RGB, corresponding with LED_SCLK	LED_R1	57	58	LED_R2	RGB output of part B: A total of 8 groups of RGB, corresponding with LED_SCLK_S
	LED_G1	59	60	LED_G2	
	LED_B1	61	62	LED_B2	
	LED_R3	63	64	LED_R4	
	LED_G3	65	66	LED_G4	

	LED_B3	67	68	LED_B4	
	LED_R5	69	70	LED_R6	
	LED_G5	71	72	LED_G6	
	LED_B5	73	74	LED_B6	
	LED_R7	75	76	LED_R8	
	LED_G7	77	78	LED_G8	
	LED_B7	79	80	LED_B8	
	LED_R9	81	82	LED_R10	
	LED_G9	83	84	LED_G10	
	LED_B9	85	86	LED_B10	
	LED_R11	87	88	LED_R12	
	LED_G11	89	90	LED_G12	
	LED_B11	91	92	LED_B12	
	LED_R13	93	94	LED_R14	
	LED_G13	95	96	LED_G14	
	LED_B13	97	98	LED_B14	
	LED_R15	99	100	LED_R16	
	LED_G15	101	102	LED_G16	
	LED_B15	103	104	LED_B16	
Ground connection	GND	105	106	GND	Ground connection
	GND	107	108	GND	
RGB output of part C : A total of 8 groups of RGB, corresponding with LED_SCLK It can becomes the part A' s check back and circuit signal detection of return	LED_R17	109	110	LED_R18	RGB output of part D : A total of 8 groups of RGB, corresponding with LED_SCLK_S It can becomes the part A' s check back and circuit signal detection of return
	LED_G17	111	112	LED_G18	
	LED_B17	113	114	LED_B18	
	LED_R19	115	116	LED_R20	
	LED_G19	117	118	LED_G20	
	LED_B19	119	120	LED_B20	
	LED_R21	121	122	LED_R22	
	LED_G21	123	124	LED_G22	
	LED_B21	125	126	LED_B22	
	LED_R23	127	128	LED_R24	
	LED_G23	129	130	LED_G24	
	LED_B23	131	132	LED_B24	
	LED_R25	133	134	LED_R26	
	LED_G25	135	136	LED_G26	
LED_B25	137	138	LED_B26		
LED_R27	139	140	LED_R28		
LED_G27	141	142	LED_G28		
LED_B27	143	144	LED_B28		
LED_R29	145	146	LED_R30		
LED_G29	147	148	LED_G30		
LED_B29	149	150	LED_B30		

	LED_R31	151	152	LED_R32	
	LED_G31	153	154	LED_G32	
	LED_B31	155	156	LED_B32	
Ground connection	GND	157	158	GND	Ground connection
Save correction coefficients in module	LED_SPI_SCK	159	160	LED_SPI_SDI	Save correction coefficients in module
	LED_SPI_CS1	161	162	LED_SPI_CS2	
	LED_SPI_SDO 1	163	164	LED_SPI_SDO 2	
	LED_SPI_CS3	165	166	LED_SPI_CS4	
	LED_SPI_SDO 3	167	168	LED_SPI_SDO 4	
	LED_SPI_CS5	169	170	LED_SPI_CS6	
	LED_SPI_SDO 5	171	172	LED_SPI_SDO 6	
	LED_SPI_CS7	173	174	LED_SPI_CS8	
Extended functional interface	LED_SPI_SDO 7	175	176	LED_SPI_SDO 8	the interface to connect LCD display
	LED_M1	177	178	LCD_CTRL1	
	LED_M2	179	180	LCD_CTRL2	
	LED_M3	181	182	LCD_CTRL3	
	LED_M4	183	184	LCD_CTRL4	
	LED_M5	185	186	LCD_CTRL5	
	LED_M6	187	188	RCV_BK1	
LED_M7	189	190	RCV_BK2		
Do not connect	NC	191	192	NC	Do not connect
	NC	193	194	NC	
	NC	195	196	NC	
	NC	197	198	NC	
Ground connection	GND	199	200	GND	Ground connection